

Hinges

detachable, for welding / Steel

SPECIFICATION

Types

- Type **ST**: with fixed steel pin
- Type **MS**: with fixed brass pin
- Type **STL**: with loose steel pin
- Type **STS**: with fixed steel pin and lubricating nipple

Steel, blank

Pin

- Steel, blank (Types ST / STS / STL)
- Brass, turned, blank (Type MS)

Washer

Brass

Lubricating nipple DIN 71412-D

Steel, zinc plated



INFORMATION

Hinges GN 128 are produced from drawn weldable profiled steel extrusions.

Types ST, STS and MS feature a hinge pin fixed in the lower half of hinge. Type STL with loose steel pin allows the easy installation when attaching several hinges in parallel or if the door is very heavy.

The upper half of Type STS hinge has an additional lubricating nipple DIN 71412-D which allows the hinges to be lubricated without dismantling the hinges.

TECHNICAL INFORMATION

- List of hinges types (see page 1362)

Type **ST / STS / MS**

Type **STL**

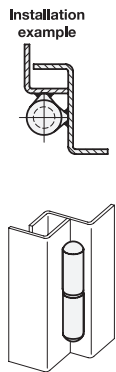
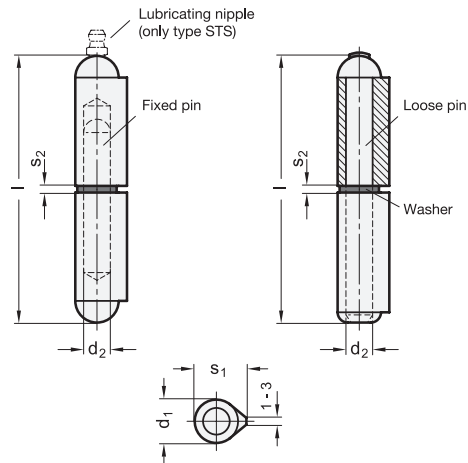

* Complete with type index of the Hinges

ST MS STL STS

GN 128

| Description | l | d1 | d2 | s1 | s2 | ⚖️ |
|--------------|------|----|----|------|----|-----|
| GN 128-40-* | 40** | 8 | 5 | 10 | 2 | 15 |
| GN 128-50-* | 50** | 8 | 5 | 10 | 2 | 19 |
| GN 128-60-* | 60** | 10 | 6 | 12 | 2 | 35 |
| GN 128-80-* | 80 | 13 | 8 | 15.5 | 2 | 83 |
| GN 128-100-* | 100 | 16 | 10 | 20 | 3 | 167 |
| GN 128-120-* | 120 | 16 | 11 | 20 | 3 | 202 |
| GN 128-135-* | 135 | 18 | 12 | 23 | 3 | 286 |
| GN 128-150-* | 150 | 20 | 13 | 25.5 | 3 | 393 |
| GN 128-180-* | 180 | 20 | 14 | 25.5 | 3 | 472 |
| GN 128-200-* | 200 | 23 | 16 | 28.5 | 3 | 680 |

** only in Type ST/MS available | Weight type MS